

Curs XIII - DTI

***Proiectarea constructivă și tehnologică a pieselor mecanice.
Extragere de detalii.***

Citirea desenului tehnic

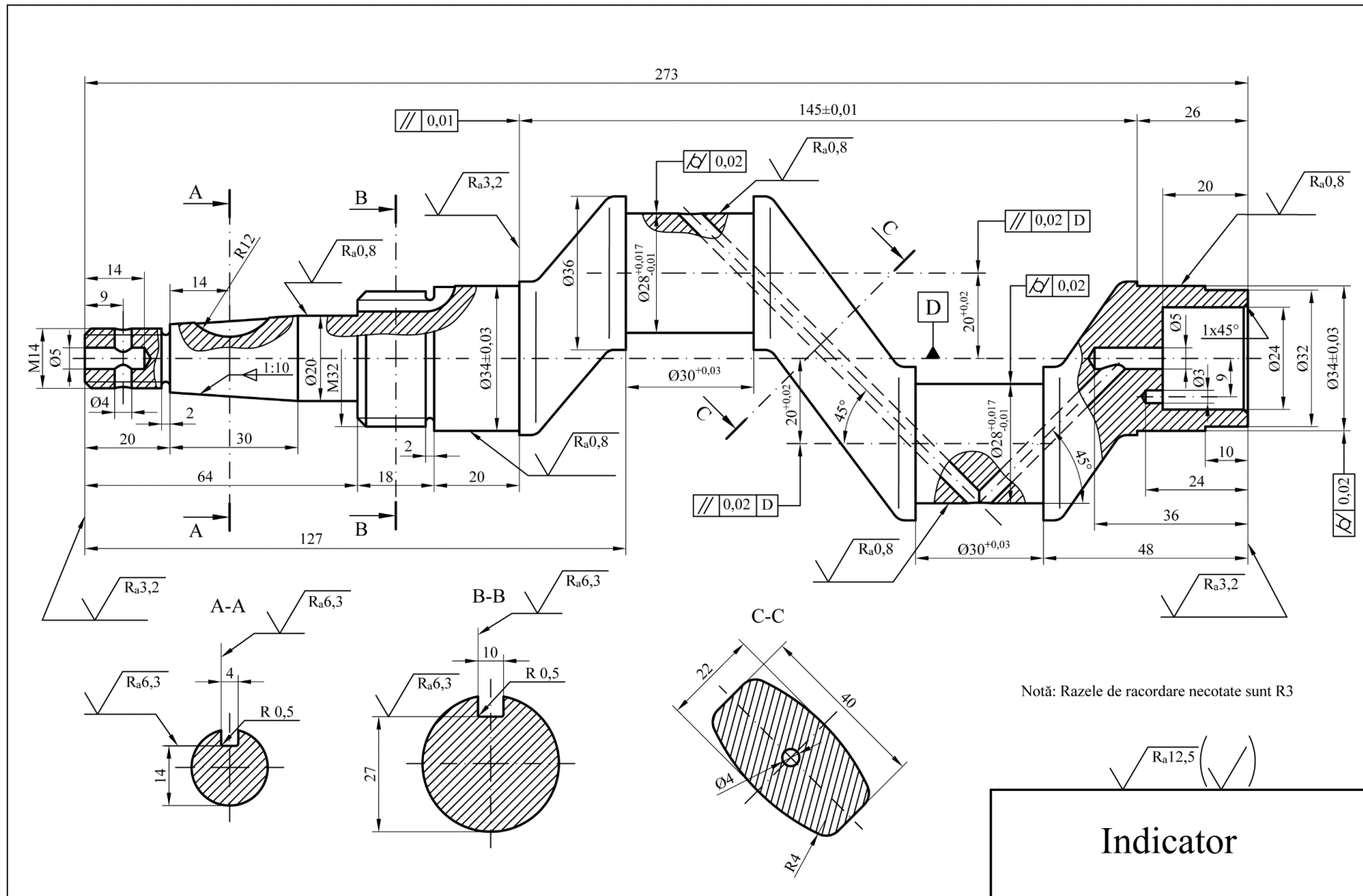

Desen de execuție arbore cotit

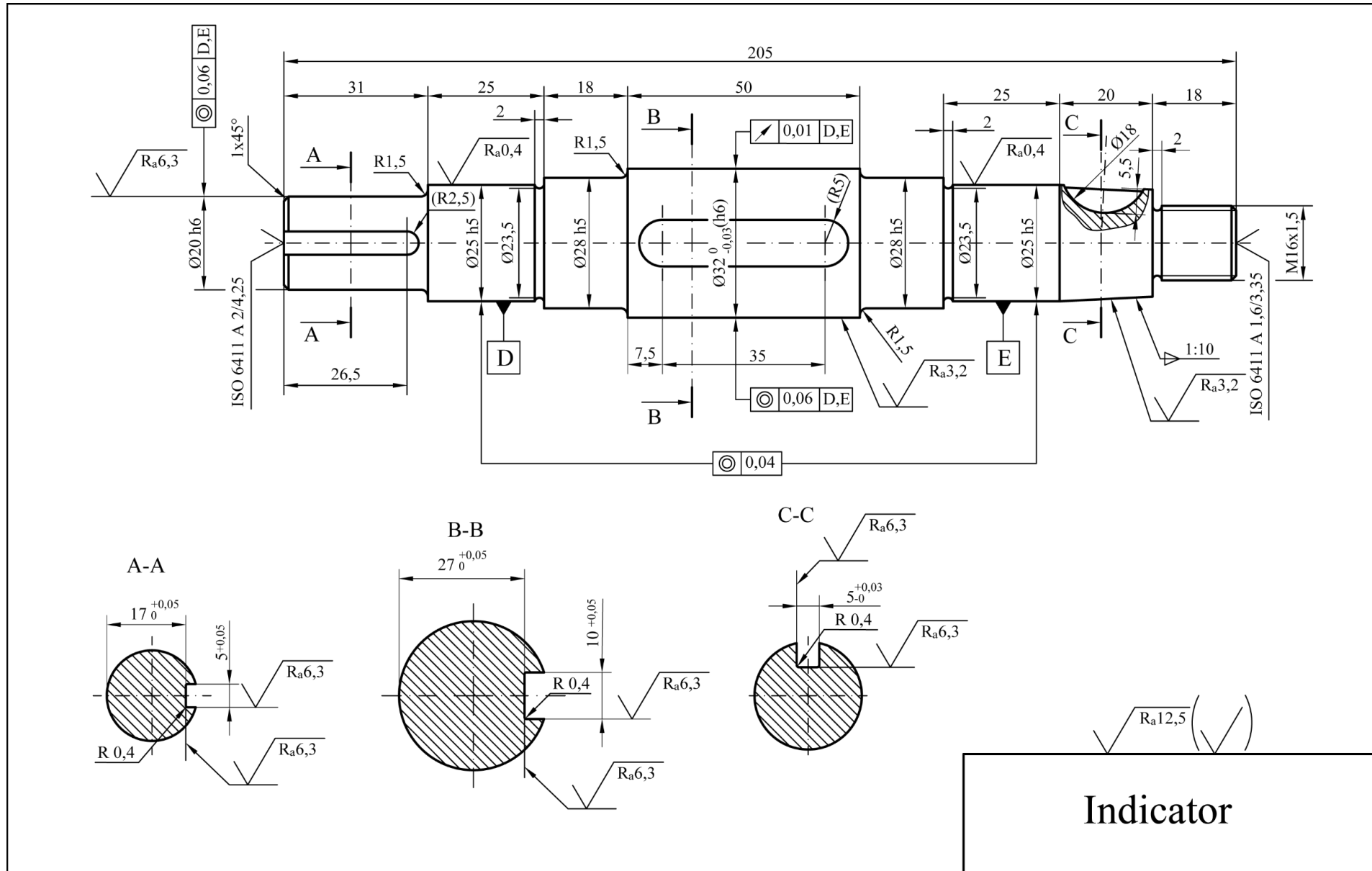

Desen de execuție arbore drept

Citirea desenului tehnic

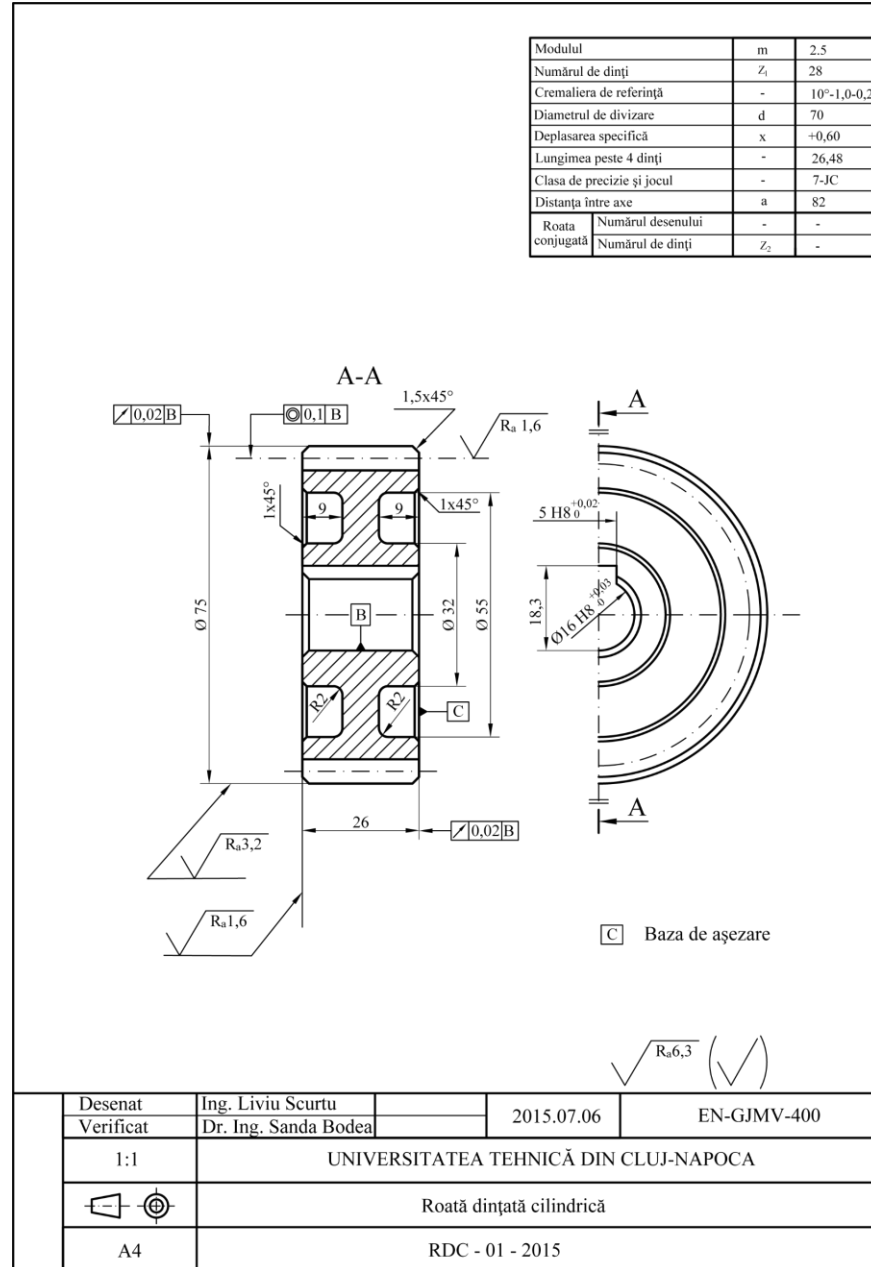

Citirea desenului tehnic

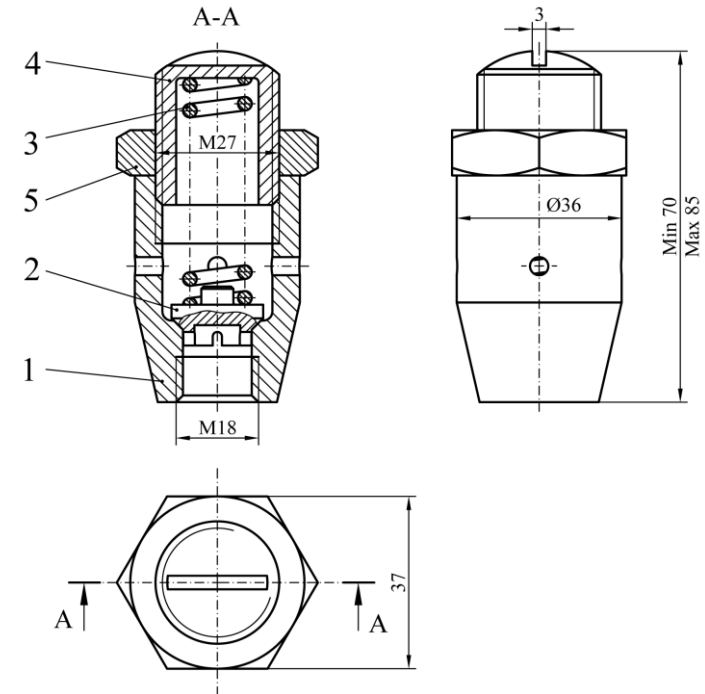
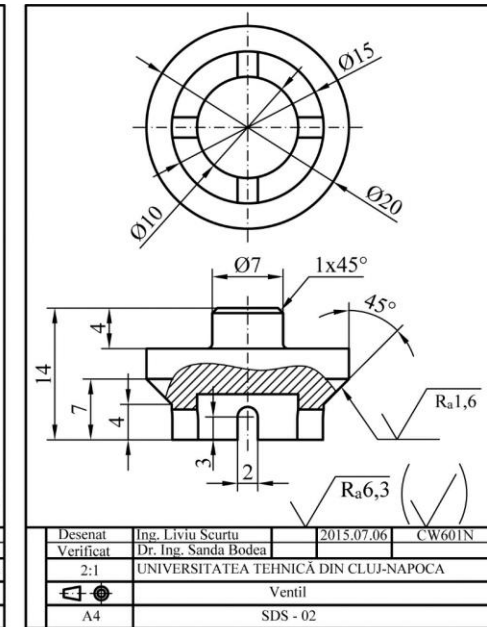
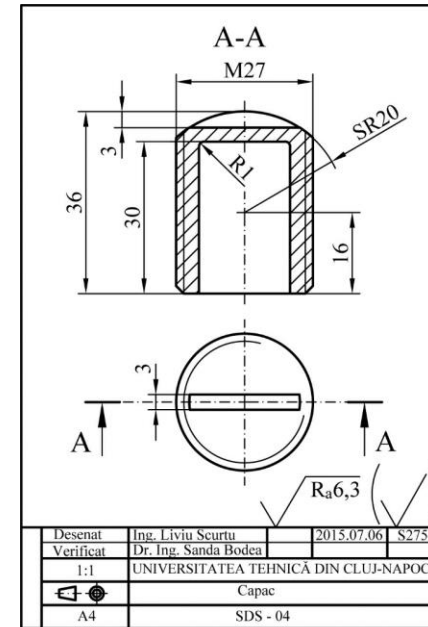
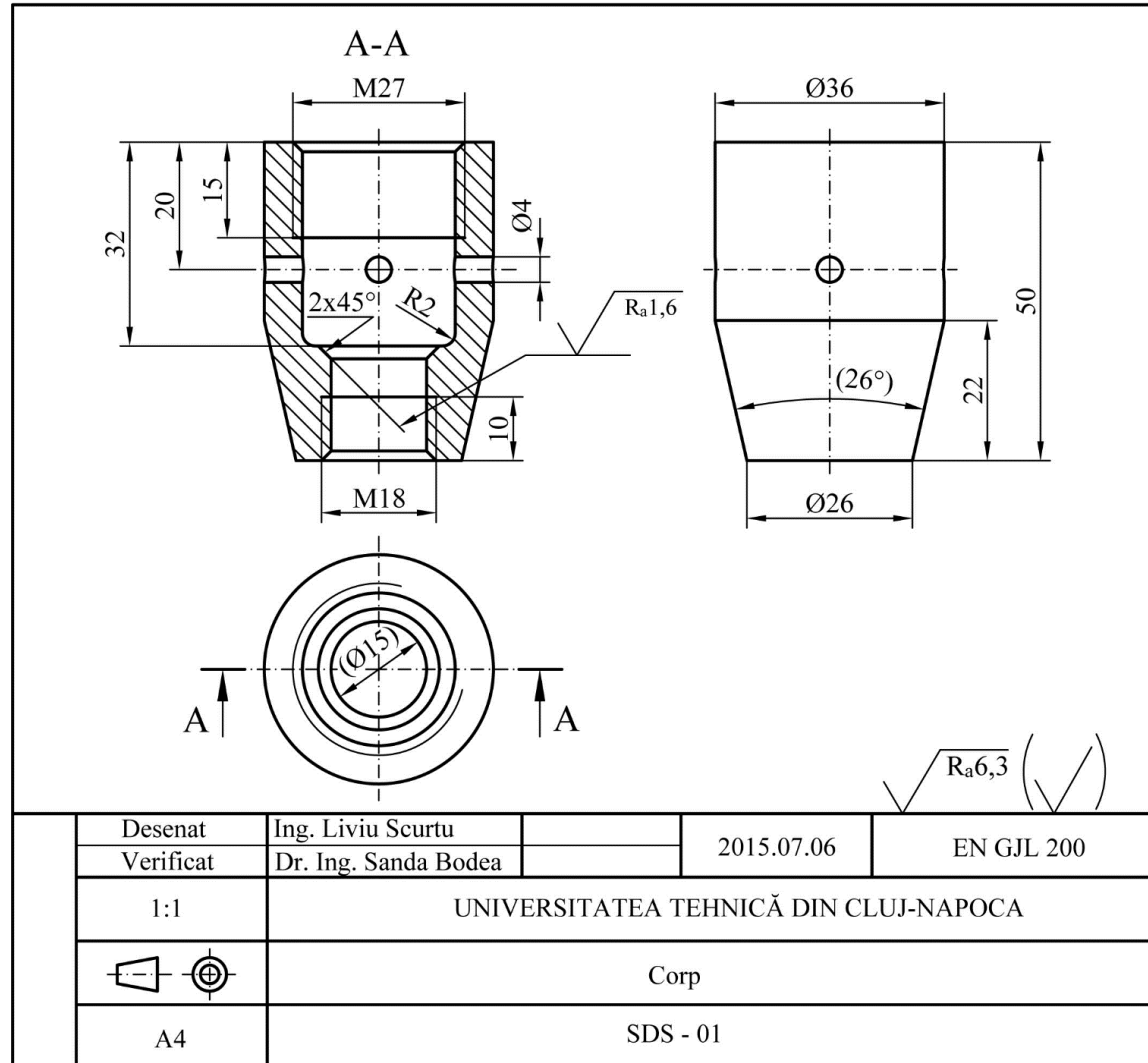

Citirea desenului tehnic

Ansamblu cu rulmenți

